

Pressure Switches

Product series DSA, DSB, DSC, DSD

For oil, fluid grease and grease

For use in SKF centralized lubrication systems, hydraulic and compressed-air systems

DSA



DSB



DSC



SKF pressure switches monitor the pressure of a centralized lubrication system to assess and help to ensure its proper function. Important monitoring parameters in an intermittently operated centralized lubrication system with SKF MonoFlex single-line distributors are pressure buildup, pressure head, and pressure reduction.

In SKF CircOil circulating-oil lubrication systems, the pressure of the pipe system and thereby the function of the centralized lubrication system are monitored.

Depending on the design, SKF pressure switches can be used for oil, fluid greases of NLGI Grades 000, 00, and 0, and NLGI Grade 1-2 greases.

SKF pressure switches are available as NC contacts, NO-contacts, or changeover contacts and monitor:

- Function of a lubrication pump unit (pressure buildup and reduction)
- Function of a directional control valve (zoned centralized lubrication systems)
- Function of a filter (degree of contamination)
- Piping (leakproof closure, etc.)



Product group DSx

Overview

Product series DSA

DSA pressure switch
Electrical connection as DIN plug in middle



DSA pressure switch
Electrical connection as DIN plug on left



DSA pressure switch
Electrical connection as DIN plug in middle



Product series DSB

DSB pressure switches



DSB pressure switch with measurement connector for a test gauge



DSB pressure switches
Dual design with pressure gauge



Product series DSC

Pressure switch DSC1



Pressure switch DSC2



Pressure switch DSC3



Product series DSD

Pressure switch DSD with screwed contacts



Pressure switch DSD with circular connector



Pressure switch DSD with rectangular plug connector



Product group DSx

Selection table

Product series	Lubricant			Switching pressure range [bar]	Electrical limit values	Temperature range [°C]	Contact type / signal output	Page
	Oil	Fluid grease	Grease					
DSA	•	•		1 – 30	250 V AC / 30 V DC	+10 to 60	Mechanical	4
DSB			•	20 – 300	30 V AC / 36 V DC	–25 to +80	Mechanical	6
DSC	•	•		0 – 100	9 – 35 V DC	–10 to +80	Electronic	10
DSD	•	•		0.5 – 45	250 V AC / 36 V DC	–10 to +100	Mechanical	13

An important criterion for the proper function of a centralized lubrication system is the period of time between starting the lubrication pump unit or the directional control valve when filling the system and the time at which the pressure switch responds. Similarly, an important criterion of pressure relief of the centralized lubrication system is the time between switching off the device and achieving a minimum residual pressure. The control unit or the machine control unit evaluates the electrical signal from the pressure switch. This data can be used for purposes such as warning messages or switching the machine off.

SKF pressure switches are available in a wide range of versions. They can therefore be used in many applications and fields, for example in machine tools and printing machines and the wind, vehicle, steel and heavy industries.

DSA pressure switches:

- For oil, fluid grease, and oiled compressed air
- Reliable switching function using microswitches
- Changeover contact
- Available with DIN or M12x1 plug
- Any mounting position
- Gold-plated contacts
- Membrane material FKM (FPM)
- Used in SKF MonoFlex single-line systems

DSB pressure switches:

- For grease
- Adaptable to lubricant distributors of product series VR due to same hole pattern, same wall distance, and same connections (G1/4)
- Changeover contact
- Gold-plated contacts
- No grease bleeding at measuring point, as the pressure switch permits continuous lubricant flow without dead space
- Used in SKF MonoFlex single-line systems and SKF DuoFlex dual-line systems

DSC pressure switches:

- For oil and fluid grease
- Various pressure units selectable
- Dual output with digital display for pressure and switching point
- Used in SKF MonoFlex single-line systems

DSD pressure switches:

- For oil and fluid grease
- Cost-effective and space-saving
- Available as NO-contact, NC-contact or CO-contact
- Used in SKF MonoFlex single-line systems

CAUTION

The important information on product usage located on the back cover applies to all systems described in this brochure.

Note

During installation, ensure that both the pressure switch is attached and the connected piping are installed without stress.

DSA pressure switches

DSA1-...-1M1A



DSA1-...-1L1A



DSA1-...-1M2A



SKF pressure switches of the DSA series are inexpensive mechanical diaphragm pressure switches. The microswitch is designed as a changeover switch and can therefore be used as both a normally closed contact (NC) and a normally open contact (NO). They are available for rising and falling pressures from 1 to 30 bar and have non-adjustable increments.

Design

The pressure cell containing the membrane and the pressure plunger is assembled with the microswitch in a compact plastic housing. The housing contains mounting feet so that the pressure switch can be mounted in any position. The electrical contacts of the microswitch are gold-plated. The membrane is made of FKM (FPM). The pressure switch housing is made of glass fiber-reinforced polyamide.

The electrical connection is established with an M12x1 circular plug or a DIN plug per DIN EN 175301-803A. Its position on the housing can be selected according to the specifics of the installation. The hydraulic connection is available as a plug connector or a solderless pipe union (DIN 3862) for pipes with diameters of 6 mm.

DSA1-...-1M1A

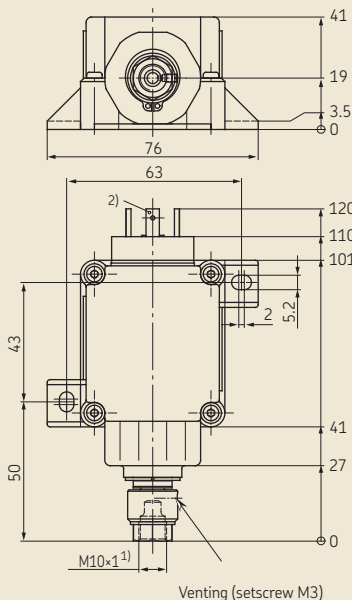

DSA1-...-2L1A

For missing dimensions, see Figure 1

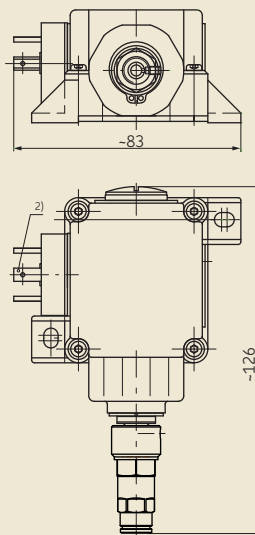

DSA1-...-1M2A

For missing dimensions, see Figure 1

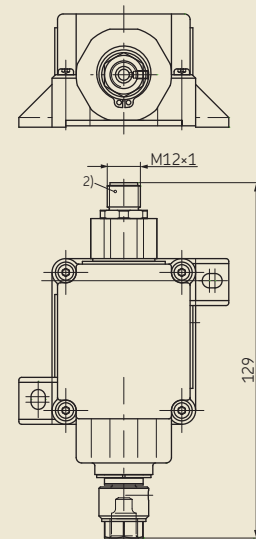

¹⁾ Pipe thread with counterbore for solderless pipe union, pipe \varnothing 6

²⁾ For connector plugs per DIN EN 175301-803A and circular plugs, cable sockets must be ordered separately; see brochure 1-1730-EN.

DSA pressure switches

Configurator

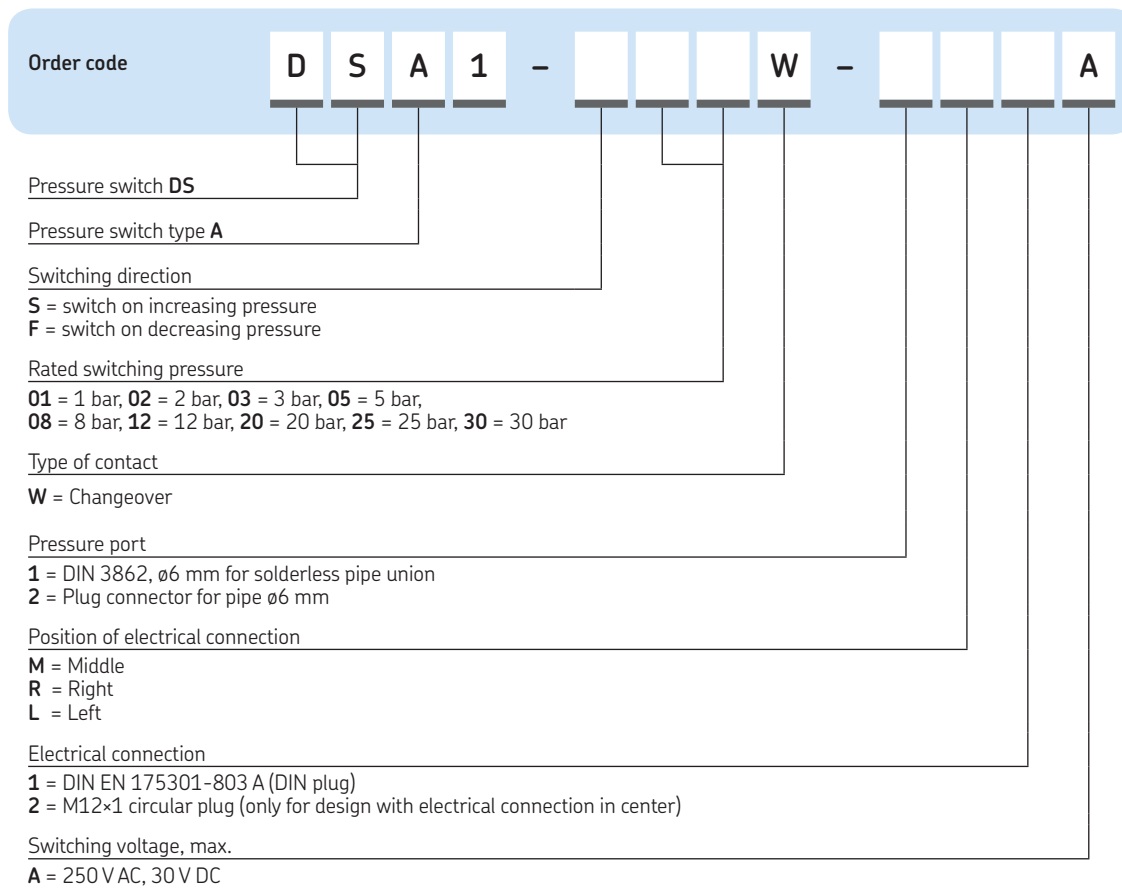

Technical data

Rated switching pressure	1 to 30 bar
Switching pressure tolerance	1 bar ± 0.3 ; 2 bar ± 0.5 ; 3 bar ± 0.5 ; 5 bar ± 0.5 ; ≥ 8 bar $\pm 0.5/-1.5$
Permissible operating pressure ¹⁾	45 bar
Contact rating, max.	125 VA
Switching voltage, max.	250 V AC / 30 V DC
Switched current	2 mA min. / 300 mA max.
Safety class IEC 61140	II
Operating temperature	+10 to 60 °C
Type of contact	Changeover
Switching rate, max.	30 per min
Mechanical service life	5 x 10 ⁶ switching cycles
Protection class (with cable box)	IP 65
Housing material	PA6 6GF30
Contact material / switch module	AuAg25Pt6
Membrane material	FKM (FPM)
Lubricant	Oil and fluid grease of NLGI Grades 000, 00, 0
Mounting position	Any

¹⁾ A pressure regulating valve must be installed in the system to prevent operating pressure from exceeding the permissible level.

Order example

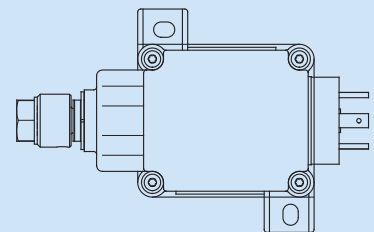

DSA1-S01W-1M1A

- Pressure switch type A
- Switches on increasing pressure
- Rated switching pressure 1 bar
- Changeover contact
- Pressure port per DIN 3862, $\varnothing 6$ mm for solderless pipe union
- Electrical connection in middle
- DIN plug DIN EN 175301-803 A
- Switching voltage 250 V AC, 30 V DC

DSB pressure switches

DSB1 pressure switch



DSB1 pressure switch with measurement connector for a test gauge



DSB1 pressure switch with pressure gauge



DSB1 pressure switch Dual design for monitoring pressure build-up and relief pressure



DSB1 pressure switch Dual design with measurement connector for a test gauge



DSB1 pressure switch Dual design with pressure gauge



SKF pressure switches of product series DSB are mechanical piston pressure switches that are specially designed for use with NLGI Grade 1-2 greases. The location of the actuating piston inside the pressure switch housing helps to ensure a continuous exchange of grease around the measuring point (pressurization point between grease and actuating piston). This reliably prevents the same grease from being pressurized repeatedly, which could cause grease bleeding (separation of the soap skeleton of the grease from the stored oil). Pressure switches of product series DSB are designed for corrosivity category C3 or C5M per ISO 12944 and are certified by Germanischer Lloyd.

Design

Based on the application, the pressure switch can be configured as a single or double design and with or without a measurement connector. The microswitch is designed as a changeover contact. This allows the circuitry to operate as an NC contact or NO-contact.

DSB pressure switches are available for rising and falling pressures from 20 to 300 bar in 10-bar increments. The pressure switch housing and the mounting rail are made of aluminum. The electrical contacts of the microswitch are gold-plated. The electrical connection is established via a DIN plug per DIN EN 175301-803A. The hydraulic connection is designed as a female thread G¹/₄.

The fastening holes, wall distance, and hydraulic connections are identical with SKF MonoFlex single-line distributors of product series V.

Pressure switch, measuring point surrounded

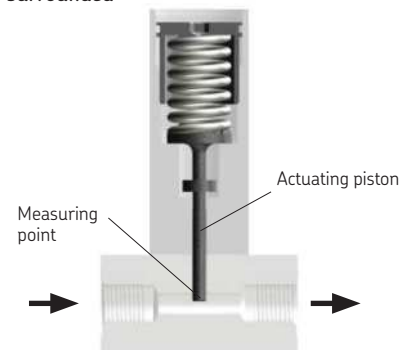

DSB pressure switches

Configurator

Order code **D S B 1** - - - - - - - - **1** - **0 1**

Pressure switch DS
Pressure switch type **B**
(for grease, 20–300 bar)

Pressure switch I
S = switch on increasing pressure
F = switching on decreasing pressure

Pressure switch I
02 = 20 bar, **03** = 30 bar, **04** = 40 ... (in 10-bar increments up to) **30** = 300 bar

Pressure switch II
0 = no pressure switch
S = switch on increasing pressure
F = switching on decreasing pressure

Pressure switch II
00 = no pressure switch
02 = 20 bar, **03** = 30 bar, **04** = 40 ... (in 10-bar increments up to) **30** = 300 bar

Measurement connector
A = measurement connector for pressure gauge M16×2 **H** = with pressure gauge 400 bar
G = with pressure gauge 250 bar **X** = no measurement connector

Electrical connection
1 = DIN EN 175301-803 A (DIN plug)

Design
A = standard, based on corrosivity category C3 per ISO 12944, certified by Germanischer Lloyd
B = based on corrosivity category C5M per ISO 12944, certified by Germanischer Lloyd, suitable for offshore applications

Design key
01 = basic design (with thread G¹/₄)

Order example

DSB1-S25000H-1A-01

- DSB1 pressure switch with a pressure switch that switches on rising pressure
- Pressure switch 250 bar
- Pressure gauge 400 bar
- Standard design, based on corrosivity category C3 per ISO 12944

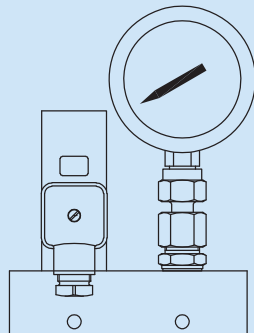

Electrical connection for DSB1*

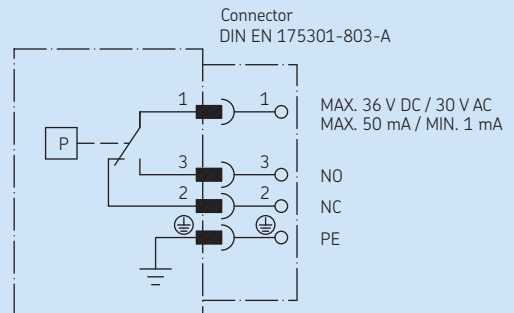

* Drawing shows non-pressurized condition

DSB pressure switches

Installation drawings

DSB1- ..

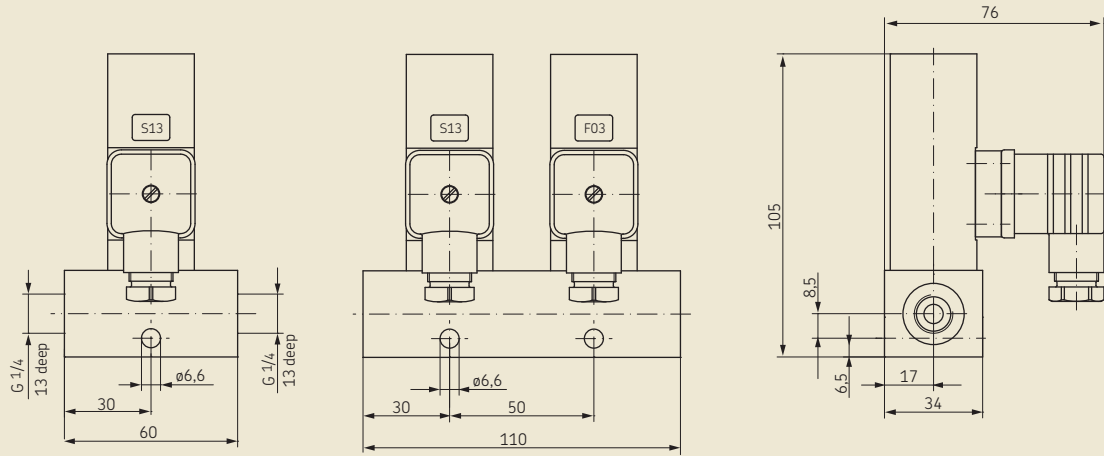

DSB1 Connectivity

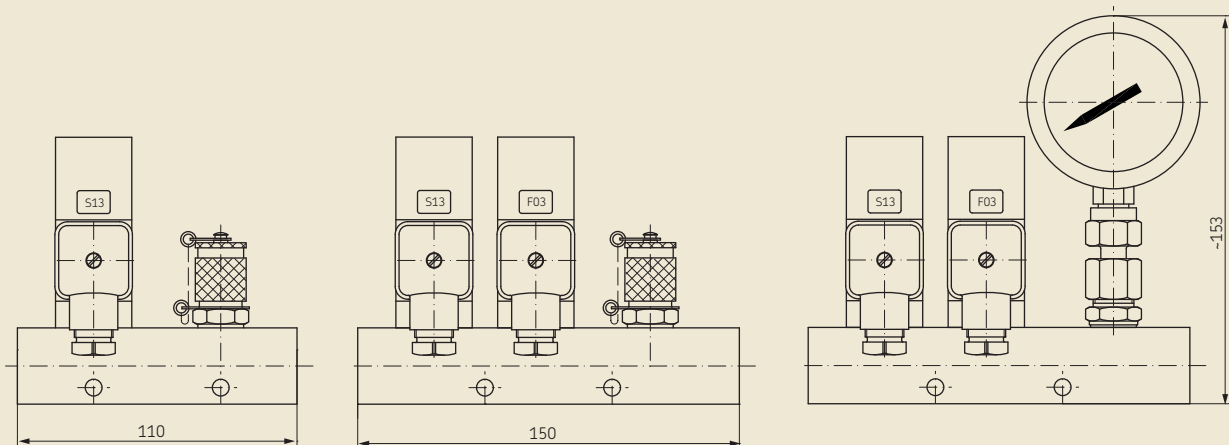

Technical data

Switching pressure, max. 300 bar
 Switching pressure tolerance $\pm 15\%$ < 100 bar;
 $\pm 10\%$ > 100 bar
 Permissible operating pressure Max. 315 bar
 Breaking capacity, ohm load Max. 1.2 VA
 Operating voltage Max. 30 V AC / 36 V DC
 Operating current Max. 50 mA, min. 1 mA
 Operating temperature -25 to +80 °C

Type of contact Changeover
 Mechanical service life 10^5 switching cycles
 Protection class per DIN EN 60529 IP65

Housing material Aluminum, anodized
 Contact material Silver alloy, hard gold plating
 Connector socket 3+PE DIN EN 175 301-803 A
 Compatible electr. line $\varnothing 4.5$ to 7 mm
 Certification Germanischer Lloyd (GL)

Lubricant Greases of NLGI Grades 1 and 2

Mounting position Any

DSB pressure switches

Accessories

169-125-003
169-140-003

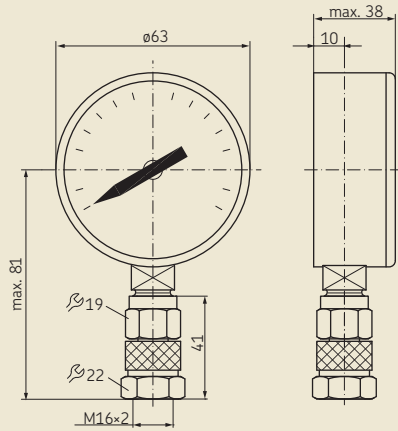

Order number Figure

Test gauge 250 bar (with fitting for measurement connector)	169-125-003	6
Test gauge 400 bar (with fitting for measurement connector)	169-140-003	6
Threaded socket for pipe 10 mm (for connecting DSB1 and VR distributors)	471-010-161	7
Straight connector (for connecting DSB1 and VR distributors)	441-110-162	7

441-110-162 (A)

471-010-161 (B)

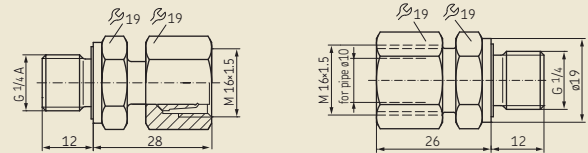

Straight connector 441-110-162 (A) and threaded socket 471-010-161 (B) for connecting DSB pressure switches and VR lubricant distributors

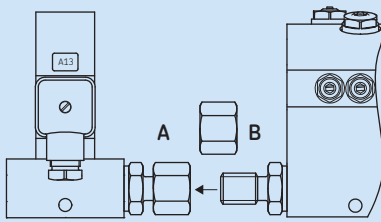

1st step: Screw the straight connector (A) tight into the pressure switch. Remove the union nut from the threaded socket (B). Screw the threaded socket (B) tight into the VR lubricant distributor.

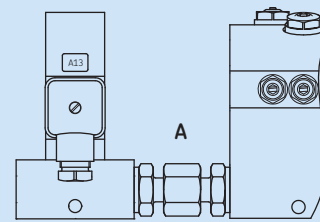

2nd step: Screw both components together tight using the union nut of the straight connector (A) of the pressure switch.

Spare parts

	Order number
Pressure gauge, 250 bar with fitting and sealing ring	169-125-000.U1
Pressure gauge, 400 bar with fitting and sealing ring	169-140-001.U1
Measurement connector	441-100-112
Connector socket	179-990-803



Note

To obtain optimum performance from the pressure switch in a centralized lubrication system, the pressure switch must always be placed **before** the last distributor.

DSC pressure switches

DSC1-A040A-1A2A



Product series DSC consists of electronic pressure switches with integrated digital display for relative pressure measurement. They are available in three different designs. They are used primarily for pressure monitoring; depending on the design, they can also assume control functions. Pressure switch points, pressure indication, and the switching logic can be configured and programmed easily.

The system pressure can be indicated in the pressure units bar, Psi and Mpa. Two independently programmable signal outputs can be used as normally open (NO) and normally closed (NC) contacts.

DSC2-A100E-2A2B



Product series DSC1

Design

DSC1 pressure switches are suitable for rising and falling pressure from 0 to 40 bar in 0.2-bar increments. Their housing is made of stainless steel and the control panel is made of polycarbonate. The values are shown by LEDs on a backlit, four-digit liquid crystal display. The electrical connection is established via an M12x1 plug connector (IP 65) and the hydraulic connection is established via a female thread of size G¹/₈. The DSC1 can operate in switching point, hysteresis, and window function modes and can be separately programmed for each output.

Features

- Encodable access protection
- Digital and analog output
- UL certification

Product series DSC2

Design

DSC2 pressure switches are suitable for rising and falling pressures from 0 to 100 bar in 0.5-bar increments. Their housing is made of aluminum and stainless steel. The control panel is made of a polyester film. The display is a four-digit digital display that indicates switching with LEDs. The electrical connection is established via an M12x1 plug connector (IP 67) and the hydraulic connection is established via a female thread of size G¹/₄. The DSC2 can operate in switching point, hysteresis, and window function modes. The switching mode can be separately programmed for each output.

DSC3-A100K-3A2B



Features

- Diagnostic output based on the DESINA specification
- UL certification

Product series DSC3

DSC3 pressure switches made of plastic are suitable for rising and falling pressures from 1 to 100 bar in 0.5-bar increments. They have a pivoted, four-digit digital display. The electrical connection is established via an M12x1 plug connector (IP 67) and the hydraulic connection is established via a T-connector with two female threads of size G¹/₈. This allows the DSC3 to be integrated ideally into a lubrication line. It can be operated in switching point or window function modes and can be separately programmed for each output.

Features

- Programming lock to protect against unauthorized adjustment of the device
- Switching displayed using LEDs

DSC pressure switches

Technical data

Technical data

Order No.	DSC1-A040A-1A2A	DSC2-A100E-2A2B	DSC3-A100K-3A2B
Rated pressure range	1–40 bar in 0.2 increments	0–100 bar in 0.5 increments	1–100 bar in 0.5 increments
Permissible overpressure	100 bar	300 bar	300 bar
Burst pressure	> 150 bar	> 650 bar	> 500 bar
Ambient temperature	–10 to +80 °C	–25 to +80 °C	–25 to +80 °C
Vibration resistance, max.	10 g (5–500 Hz)	20 g (10–2000 Hz)	10 g (5–500 Hz)
Service life	100×10 ⁶ pressure changes	100×10 ⁶ pressure changes	100×10 ⁶ pressure changes
Protection class	IP65	IP67	IP67
Material	Aluminum	Stainless steel	Plastic
Mounting position	Any	Any	Any
Electrical characteristics			
Operating voltage	10–32 V DC	18–30 V DC	9–35 V DC
Power consumption, max.	50 mA	35 mA	35 mA
Current-carrying capacity	0.5 A	0.15 A	1.2 A
Number of signal outputs	2	2	2
Type of signal outputs	PNP transistor stages	PNP/NPN	PNP transistor stages
Electrical connection M12×1	5-pin	4-pin	4-pin
Pressure port	G ¹ / ₈	G ¹ / ₄	G ¹ / ₈

Installation drawings

DSC1-A040A-1A2A

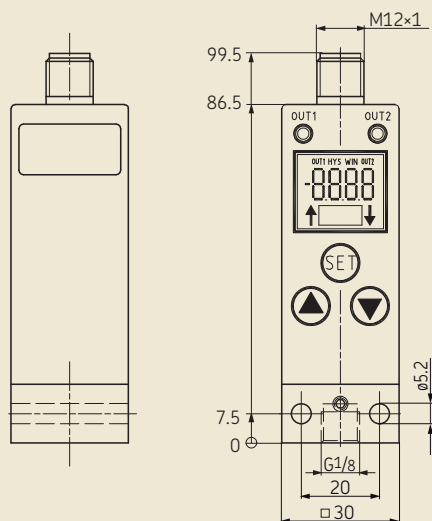

Electrical connection for DSC1

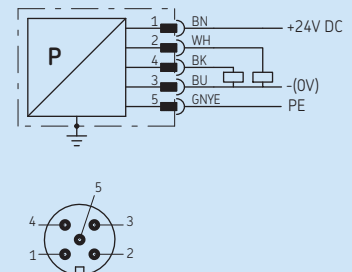

DSC1 connector pin assignment

Pin	Function	Wire color *)
1	(+)	Brown (BN)
2	Output 2	White (WH)
3	(–)	Blue (BU)
4	Output 1	Black (BK)
5	PE	Green/yellow (GR/YE)

*) When using a customized cable with cable socket, see brochure 1-1730-EN.

DSC pressure switches

Installation drawings

DSC2-A100E-2A2B

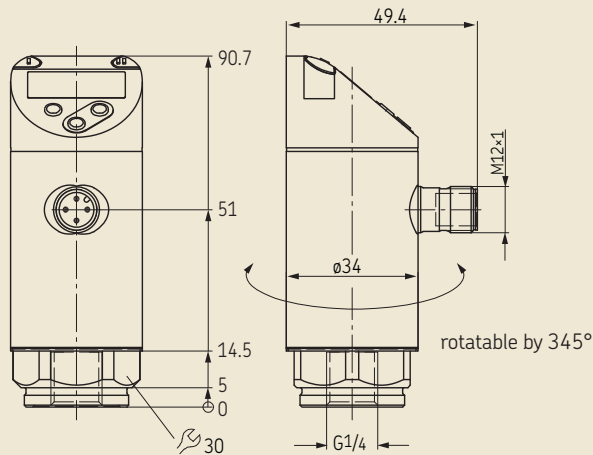

Electrical connection for DSC2

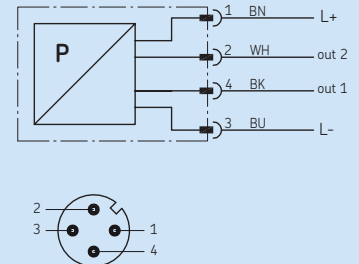

DSC2 connector pin assignment

Pin	Function	Wire color *)
1	(+)	Brown (BN)
2	Output 2	White (WH)
3	(-)	Blue (BU)
4	Output 1	Black (BK)

*) When using a customized cable with cable socket, see brochure 1-1730-EN.

DSC3-A100K-3A2B

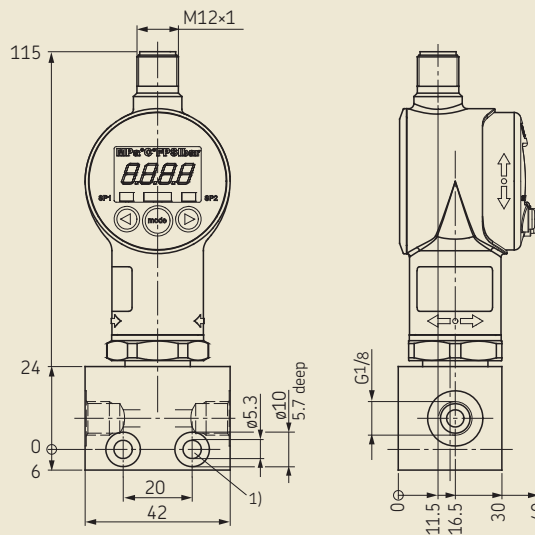

1) Counterbore per DIN 974-1 (2 M5 fastening bolts and lock washers are supplied detached)

Electrical connection for DSC3

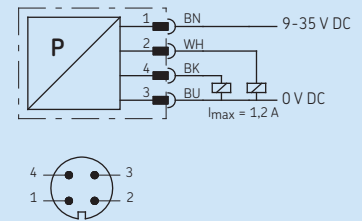

DSC3 connector pin assignment

Pin	Function	Wire color *)
1	(+)	Brown (BN)
2	Output 2	White (WH)
3	(-)	Blue (BU)
4	Output 1	Black (BK)

*) When using a customized cable with cable socket, see brochure 1-1730-EN.

DSD pressure switches



Product series DSD consists of mechanical diaphragm pressure switches. They are available as normally open (NO) or normally closed (NC) contacts for a pressure range from 0.5 to 45 bar with fixed increments. Their electrical contacts are silver-coated, the membranes are made of NBR, and the pressure switch housing is made of galvanized steel (Cr6-free). The electrical connection is established via screwed contacts, tab connectors, circular connectors, or rectangular plug connectors. The hydraulic connection is designed as a male thread M10x1 taper.

Function of NO-contact

The membrane (2) is pressurized through the pressure port (1). If the resulting pressure is greater than the preloaded spring force of the pressure spring (3), a pressure plunger (4) that carries the contact washer (5) moves to the opposing contact (6) and closes the circuit.

If the pressure is reduced by the amount of hysteresis, the switch opens again. On an NC contact, contacts are made in the opposite way.

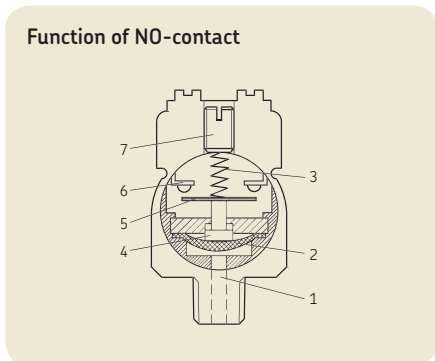

Technical data

Rated switching pressure	0.5 – 45 bar
Switching pressure tolerance for pressure switch ¹⁾	
with screwed contacts	0.5 bar +0.3/-0.1; 2–8 bar ±0.5; 12 bar +0.5/-1.5; 20 bar ±1; 28 bar +2/-1; 45 bar ±2
with tab connector/screwed contacts, circular and rectangular plug connector	0.5 bar ±0.1; 2–3 bar ±0.3; 8 bar ±0.5; 12–20 bar ±1; 28–45 bar ±2
Max. perm. operating pressure, static/dynamic	300 bar/150 bar
Max. contact rating for pressure switch	
with screwed contacts	90 VA
with tab connector/screwed contacts and circular connector	18 VA
with rectangular plug connector	100 VA
Max. switching voltage/switched current ²⁾ for pressure switch	
with screwed contacts	36 V DC / 2.5 A
with tab connector/screwed contacts and circular connector	36 V DC / 0.5 A
with rectangular plug connector	36 V DC / 2.5 A 250 V AC / 5 A
Operating temperature for pressure switch	
with screwed contacts	-30 to +100 °C
with tab connector/screwed contacts, circular and rectangular plug connector	-10 to +100 °C
Type of contact for pressure switch	
with screwed contacts, circular and tab connector/screwed contacts	NC- or NO-contact
with rectangular plug connector	CO-contact
Max. Switching rate for pressure switch ³⁾	
with screwed contacts	60 cycles/min
with tab connector/screwed contacts and circular connector	5 (200) cycles/min
with rectangular plug connector	5 (60) cycles/min
Mechanical service life	10 ⁶ switching cycles
Type of protection housing	IP 65
Type of protection connection terminals	IP 00
Material	
Membrane material	NBR
Housing material	Steel, galvanized, Cr6-free
Contact material / switch module	versilbert
Lubricant	Oil and fluid grease of NLGI Grades 000, 00, 0
Mounting position	Any

¹⁾Tolerances at +20°C

²⁾ Resistive load

³⁾ Consider EMC measures at more than 5 cycles/min.

DSD pressure switches

Configurator

Order code	D	S	D		-	A					N	-			A	1	
Pressure switch DS	-----		-----														
Pressure switch type D	-----																
Manufacturer marking	-----																
1 = Marking 1 (only with electrical connection 1) 3 = Marking 3 (only with electrical connection 2-4)																	
Type A	-----																
Rated switching pressure																	
0005 = 0.5 bar, 0020 = 2 bar, 0030 = 3 bar, 0080 = 8 bar 0120 = 12 bar, 0200 = 20 bar, 0280 = 28 bar, 0450 = 45 bar																	
Membrane material NBR = N	-----																
Type of contact																	
NC = Closed (only with electrical connection 1-3 available) NO = Open (only with electrical connection 1-3 available) CO = Changeover (only with electrical connection 4 available)																	
Contact material	-----																
A = Silver contacts																	
Pipe thread	-----																
1 = M10×1 tap.																	
Electrical connection																	
1 = Screwed contacts M3 2 = tab connector 6,3×0,8/screwed contacts M3 3 = circular connector M12×1 4 = rectangular plug connector DIN EN 175301-803-A (only as changeover (CO) available)																	

Order example

DSD1-A0005-N0A11

- Pressure switch type D
- Manufacturer marking 1
- Typ A
- Switching pressure 0.5 bar
- Membran material NBR
- NC-contact
- Pipe thread M10×1 tap.
- Electrical connection screwed contacts

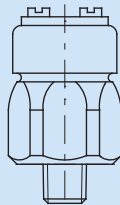

DSD pressure switches

Installation drawings

DSD with screwed contacts (1)

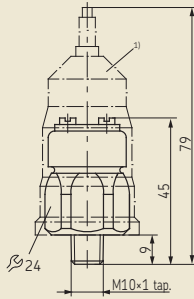

1) Cap, order No. 898-420-001, is ordered separately.

DSD with tab connector/
screwed contacts (2)

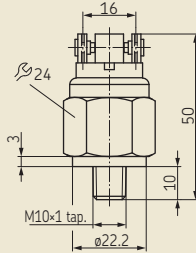

DSD circular connector (3)

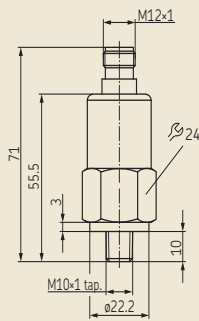

Electrical connection DSD circular connector (3)

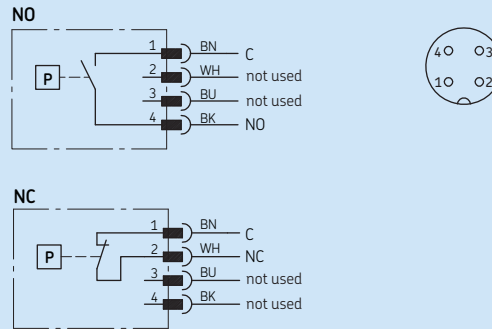

DSD rectangular plug connector (4)

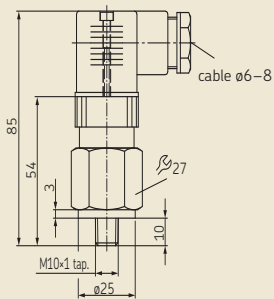

Electrical connection DSD rectangular plug connector (4)

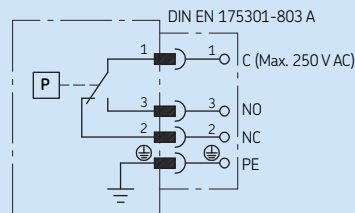

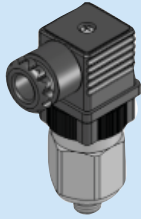

CAD models for the products shown in this brochure can be downloaded at:
skf-lubrication.partcommunity.com

! Important information on product usage

SKF and Lincoln lubrication systems or their components are not approved for use with gases, liquefied gases, pressurized gases in solution and fluids with a vapor pressure exceeding normal atmospheric pressure (1.013 mbar) by more than 0,5 bar at their maximum permissible temperature.

Further brochures:

- 1-0103-EN Fittings and Accessories*
- 1-1730-EN Electrical Plug-In Connections*
- 1-9201-EN Transport of Lubricants in Centralized Lubrication Systems*

SKF Lubrication Systems Germany GmbH

Berlin Plant
Motzener Str. 35/37 · 12277 Berlin
PO Box 970444 · 12704 Berlin
Germany

Tel. +49 (0)30 72002-0
Fax +49 (0)30 72002-111

This brochure was presented to you by:

© SKF is a registered trademark of the SKF Group.

© SKF Group 2016

The contents of this publication are the copyright of the publisher and may not be reproduced (even extracts) unless prior written permission is granted. Every care has been taken to ensure the accuracy of the information contained in this publication. However, no liability can be accepted for any loss or damage whether direct, indirect or consequential, arising out of use of the information contained herein.

PUB LS/P2 11679 EN · August 2016 · 1-1701-EN

This brochure replaces brochure 1-1701-1-EN.

